

niglon

Circuit Protection



EM3220L Modular Enclosures Metal Clad

Technical Drawing

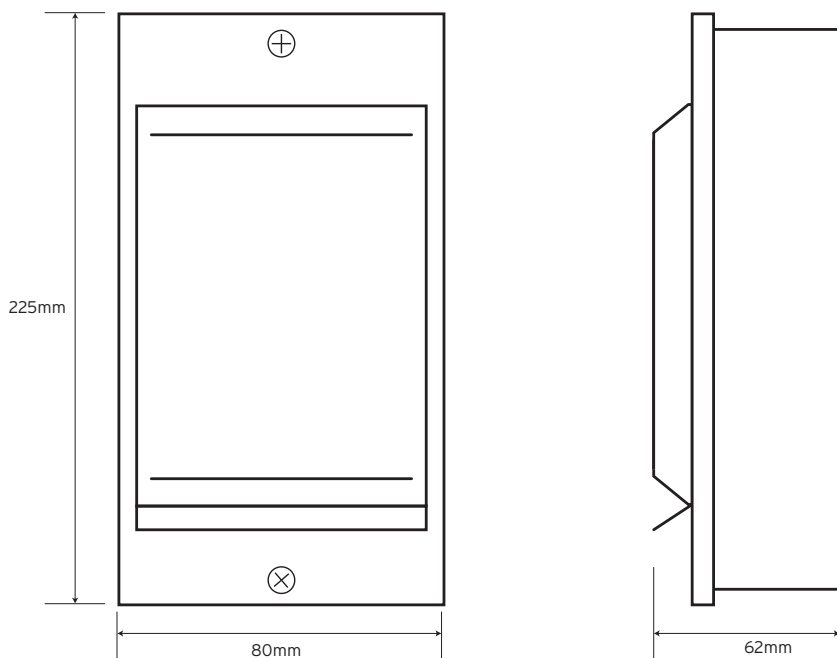

Technical Specifications

Module No.	2
Extra	c/w drop lid
Standard of Compliance	BS EN 60898 & 61008 IP20 Amendment 3 Compliant
Dimensions	225x80x62mm (H x W x D)