

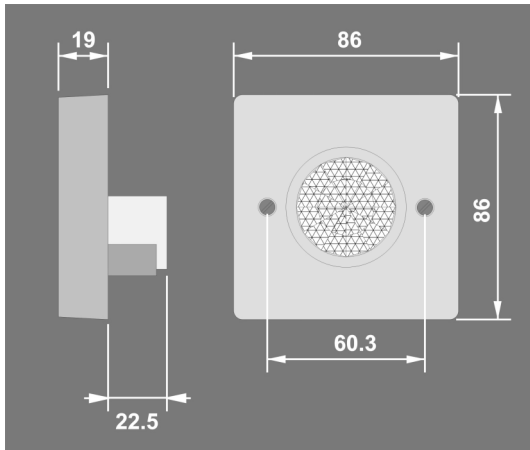

SPIR-F/C Product Guide

Ceiling Presence Detector

Overview



The SPIR-F/C presence detector switches are designed to provide automatic control of lighting, heating or ventilation loads. They detect movement using a PIR sensor and turn the load on. When an area is no longer occupied the load will switch off after an adjustable time out period.

An adjustable internal light sensor provides additional energy saving in lighting applications. When an area is occupied lighting is only switched on when the level of natural light is below a preset level.

When the unit is first powered up the PIR sensor will always detect immediately regardless of whether the room is occupied.

Wiring

Wire the SPIR-F/C products as in the diagram.

To switch from more than one position simply wire two or more units in parallel to achieve two way and intermediate switching.

The detector should be sited so that the occupants of the room fall inside the detection pattern shown overleaf, at a recommended height of 3-4m on the ceiling. Note that the lower the sensor is installed the smaller the detection range will be, subject to the parameters shown on the diagram.

- Avoid direct sunlight entering the sensor.
- Do not site within 1m of forced air heating or ventilation.
- Do not site within 1m of any lighting.
- Do not fix to a vibrating surface.

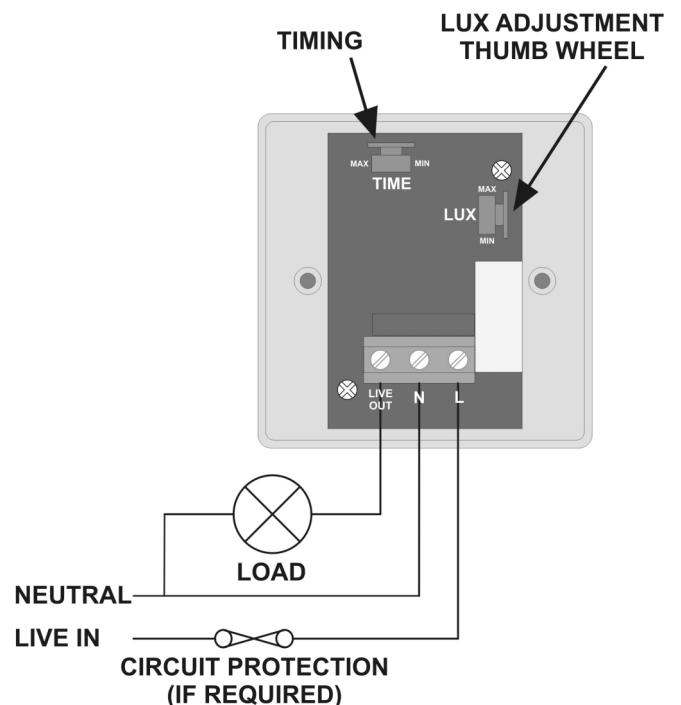

Installation

Warning. This device works at mains potential. Be sure to take care when working with electricity.

1. Make sure the load is connected and in working order.
2. Isolate the mains supply to the circuit at the main consumer unit.
3. Connect the controller via the terminal block. Live supply to the L terminal, Neutral to the N terminal and the load to the LIVE OUT terminal.
4. Set the LUX level to maximum and the time to minimum.
5. Switch the mains supply back on at the distribution board.
6. The load should come on immediately.
7. Vacate the room or remain very still and wait for the load to switch off (should take no more than 2 minutes).
8. Check that the load switches on when movement is detected.
9. To set the final LUX level wait until the level of natural daylight is just enough that lighting is required. Starting with the LUX control fully clockwise (at minimum), very slowly turn the control anti-clockwise until the lights come on. Note that when the LUX control is at maximum then the lights will **always** come on with occupancy.
10. Set the time required.

Detection Pattern

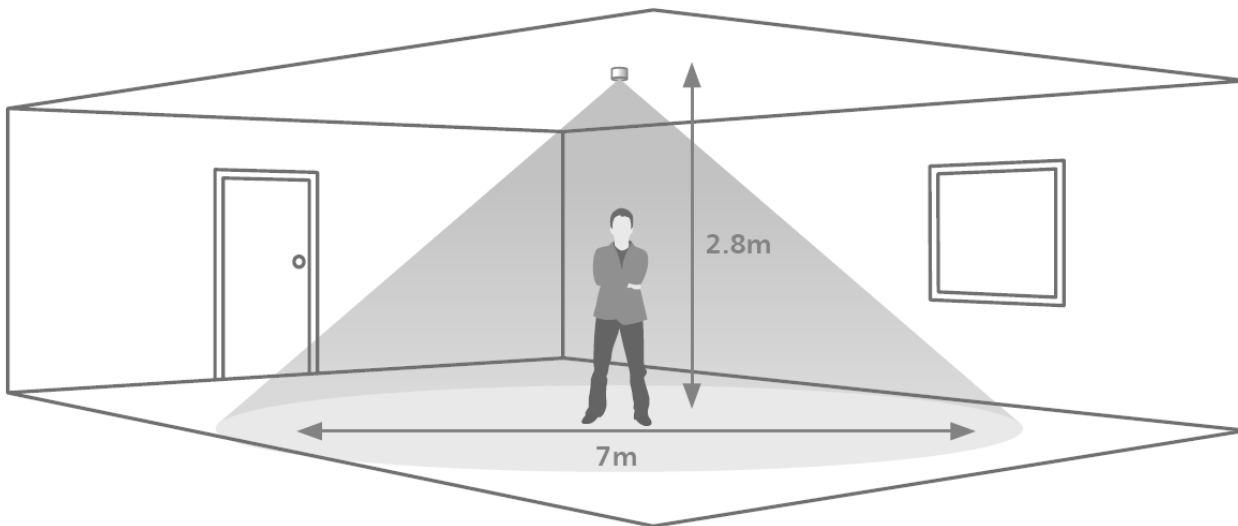

Area of high sensitivity  Area of lower sensitivity 

Fault Finding

LOAD DOES NOT COME ON

Check to see if the live supply to the circuit is good. Strap across the *L* and *LIVE OUT* terminal to turn the load on.

If the supply and wiring are good, check the LUX level setting. Increase the LUX level setting to allow the controller to turn on at higher ambient natural light level.

If the detection range is smaller than expected, check the diagram above. Rotating the sensor slightly may improve the range.

LIGHTS DO NOT GO OFF

Ensure that the area is left unoccupied for longer than the selected timer setting.

Make sure that the sensor is not adjacent to circulating air, heaters or lamps.

Specification

LOAD

16 Amp resistive load
 10 Amp incandescent lighting
 6 Amp fluorescent lighting
 3 Amp compact fluorescent lighting
 3 Amp low energy lighting
 3 Amp low voltage lighting (switch primary of transformer)
 Fluorescent lighting (max 6 fittings recommended)
 For fluorescent lighting total power factor correction capacitance must not exceed 40µF.
 3 Amp fans and ventilation equipment
 Switch SON lighting loads via a contactor

SUPPLY VOLTAGE 220-240 Volts AC 50 Hz
TIME OUT PERIOD Adjustable 10 seconds to 30 minutes
LIGHT LEVEL Light to dark.
FIXING METHOD Surface fixing 25mm deep plastic surface mount moulded box.
 Flush fixing 25mm steel wall box or 32mm deep cavity wall box.

TERMINAL CAPACITY 4.0mm²
MATERIAL Flame retardant ABS
TYPE Class 2
TEMPERATURE -10°C to 35°C
CONFORMITY EMC-2004/108/EC
 LVD-2006/95/EC



Part Numbers

SPIR-F/C Ceiling mounted presence detector c/w internal lux sensor

IMPORTANT NOTICE!

This device should be installed by a qualified electrician in accordance with the latest edition of the IEE Wiring Regulations and any applicable Building Regulations.



C.P. Electronics Ltd
 Brent Crescent
 London
 NW10 7XR
 United Kingdom
 Tel: + 44 (0) 333 900 0671
 Fax: + 44 (0) 333 900 0674
www.green-iswitches.co.uk
enquiry@green-iswitches.co.uk