

Just E3 Plug&play Kit Manual Test LiFePO4



- EN** Installation Instructions
- DE** Montageanleitung
- CZ** Montážní návod
- DK** Monteringsvejledning
- EE** Paigaldusjuhend
- FI** Asennusohje
- FR** Notice de montage
- HU** Szerelési útmutató
- HR** Uputstvo za montažu
- NL** Montagehandleiding
- RO** Instructuni de montaj

- IT** Istruzioni di montaggio
- LT** Montavimo Instrukcijos
- LV** Instalācijas instrukcija
- NO** Monteringsanvisning
- PL** Instrukcja montażu
- SE** Installationsanvisning
- RU** Инструкция по монтажу
- SRB** Instrukcija za instalaciju
- SK** Montážny návod
- SLO** Navodilo za montažo
- CN** 安装说明书



1. Installation and commissioning may only be carried out by authorized specialists and wired in accordance with the latest IEE electrical regulations or the national standards.
2. Mains power must be switched off before carrying out installation.
3. The manufacturer, shall not be liable for any damage resulting from inappropriate modifications to the luminaire or faulty installation.
4. Light source can't be replaced.
The control gear provides basic insulation between the LV supply and the control circuit.



SAP Code	Product Description	Input	Wattage	Operation Temperature
96635766	JUST E3 PLUG&PLAY KIT MANUALTEST LIFEPO4	AC 220-240V 50-60Hz	3W	0-+50°C

YH25

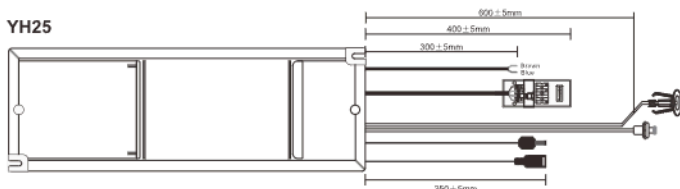

1

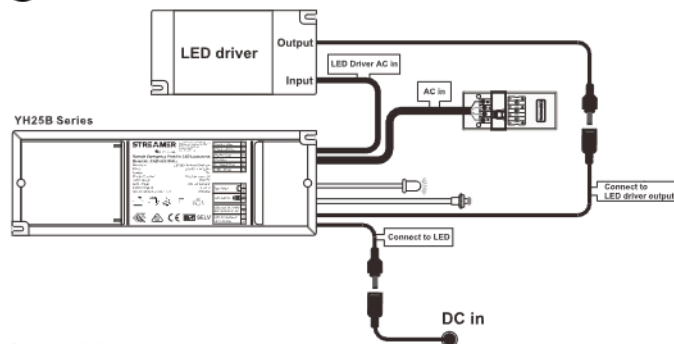

Compatible with



Anna Vario



Amy Vario



Zoe Vario



Lily

2



Make a 20mm cutting hole



3

L1: Unswitched Line N : Neutral
L : Switched Line

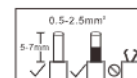
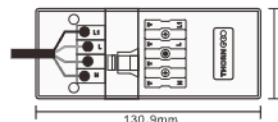

4 A. Connect the battery

1. Open the battery hatch

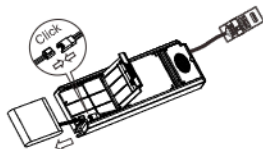

2. Connect the battery plug



3. Close the hatch

B. Mark installation date

Please indicate the date of installation on this label.

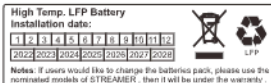
**5** Fill in 4-digit code on back of the product 

		1		A		180
X	Self-contained	0	Non-Maintained	A	Including test device (Manual Test)	180
		1	Maintained	F	Self-test according to IEC 61347-2-7, EL-T marked	

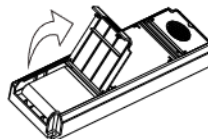
6 A. Replace the battery (Order 59011337 )

1. Open the battery hatch

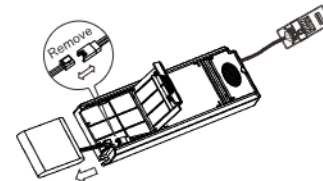

2. Remove the battery and disconnect the plug





3. Put the battery in the battery box and close it

B. Mark installation date

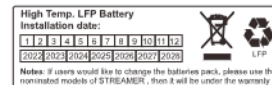
Please indicate the date of installation on this label.

**Explanation of LED indicator**

	Color	LED indication	Status	Comment
	Green	Permanent green	Charging Mode Fully Charged	AC mode
		Green and red off	DC mode	Battery operation (emergency mode)

